



Visit our homepage  
for additional support  
[parker.com/pmde](http://parker.com/pmde)

Bulletin MSG30-8205-INST/EU

# Installation and Startup Manual Hydraulic Motors Series F10/F11/F12

Effective: December, 2021

Supersedes: March, 2018

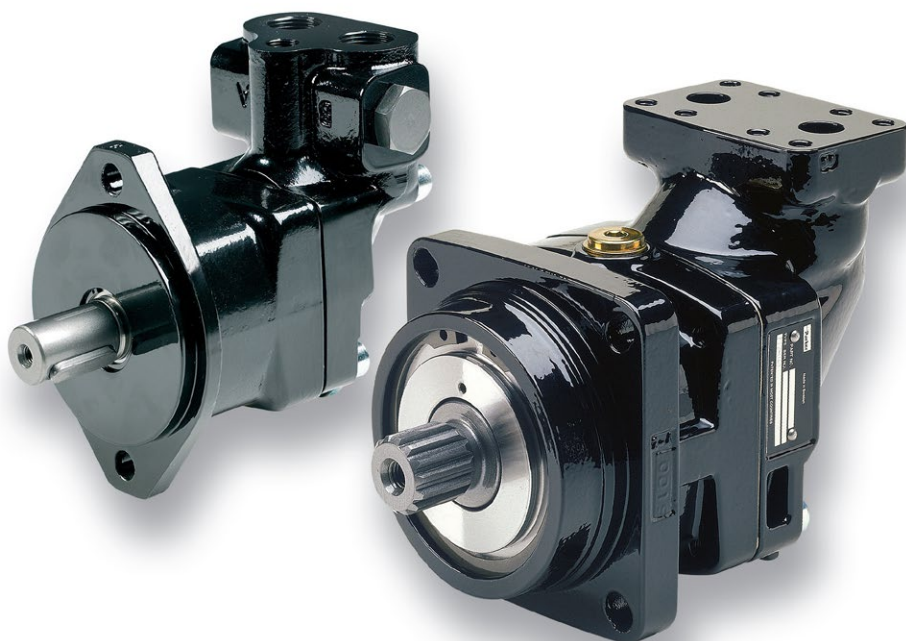

Language

SE, UK, DE, FR, ES, SF, IT, RU, ZH



ENGINEERING YOUR SUCCESS.

**VIKTIGT • IMPORTANT • IMPORTANTE • WICHTIG •  
TÄRKEÄTÄ • ВАЖНО • 重要事項:**

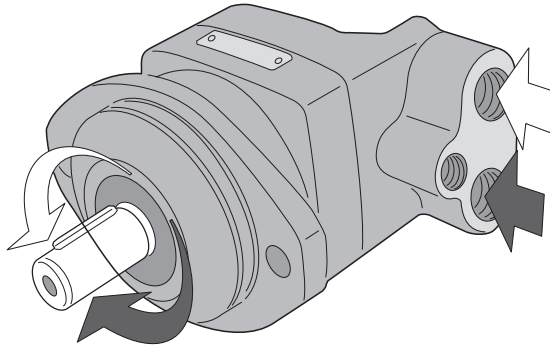

- SE** Rotationsriktning flödesriktning. Gäller både pump och motor.
- UK** Direction of rotation corresponding FLOW direction. Apply to both pump and motor.
- DE** Drehrichtung entsprechend der Durchflußrichtung. Paßt sowohl für Pumpe als auch Motor.
- FR** Sens de rotation – Sans de débit correspondant – Valable également pour les pompes et les moteurs.
- ES** El sentido de giro corresponde a la dirección del caudal. Esto es aplicable tanto en bombas como en motores.
- SF** Pyörimissuunta virtaussuunta. Koskee sekä pumpputta että moottoria.
- IT** Senso di rotazione in funzione della direzione di mandata. Vale indifferentemente, sia come pompa, che come motore.
- RU** Направление вращения соответствует направлению ПОТОКА. Это относится и к насосу, и к двигателю.
- ZH** 适用于泵与马达工况
- SE** Garantien endast giltigt om pump/motor ej är isärtagen.
- UK** The guarantee is only valid if the pump/motor has not been disassembled.
- DE** Die Garantie gilt nur, wenn Pumpe/Motor nicht zerlegt sind.
- FR** La garantie est valable uniquement moteur/pompe non démonté(e).
- ES** La garantía solo es válida si la bomba/el motor no ha sido desarmada/o.
- SF** Takuun voimassaolo päättyy, jos pumpputta/moottoria on purettu.
- IT** La garanzia è valida a condizione che pompa/motore non siano smontati.
- RU** Гарантия распространяется только на насосы / двигатели, которые не были разобраны.
- ZH** 泵/马达仅在未拆解的情况下才提供保修

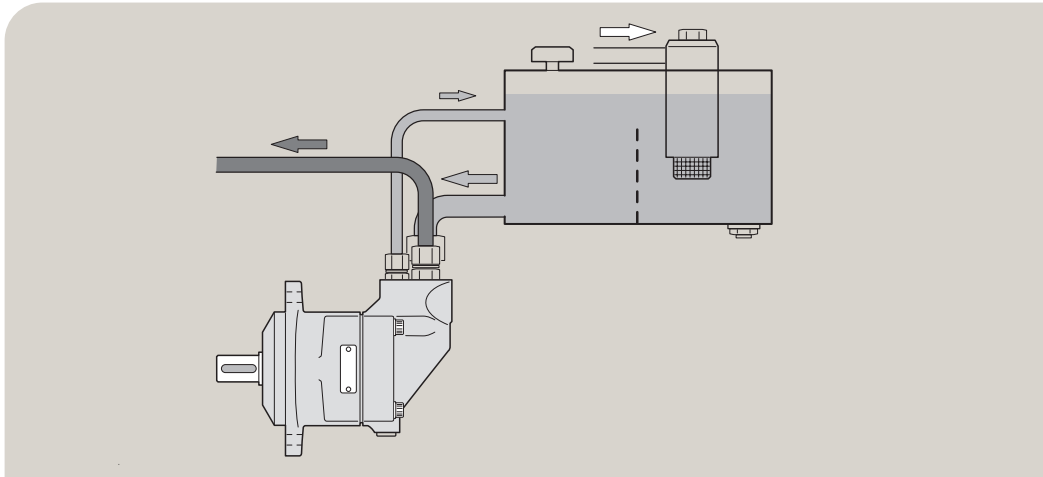

- SE** Använd våra rekommenderade ledningsdimensioner. Smala sugledningar och krökar kan orsaka kavitation, som medför oljud och skador.
- UK** Follow our recommendations regarding pipe dimensions. Narrow pipes and bends can cause cavitation, which will generate unnecessary noise and damage.
- DE** Beachten Sie unsere Empfehlungen bezüglich Rohrabmessungen. Dünne Rohre und starke Biegungen können Kavitationen hervorrufen, die unnötige Geräusche und Schäden verursachen.
- FR** Prière de suivre nos recommandations concernant les diamètres des tuyauteries. Des coudes et des tuyaux de diamètre trop réduit donnent lieu à du bruit et provoquent éventuellement une détérioration du matériel
- ES** Siga nuestras recomendaciones respecto al tamaño de las tuberías. Tubos y codos estrechos pueden causar cavitación, lo cual dará lugar a averías y ruidos innecesarios.
- SF** Käytä suosittelimamme kokoisia putkia. Ohuet imuputket ja putkikäyrät voivat aiheuttaa kavitaatiota, seurauksena melua ja vaurioita.
- IT** Seguire le nostre raccomandazioni circa il dimensionamento del diametro delle tubazioni. Diametri insufficienti e curve strette possono creare cavitazione, e conseguentemente rumorosità superflua e ulteriori danni.
- RU** Следуйте нашим рекомендациям, касающимся размеров труб. Тонкие трубы и значительные сгибы могут привести к кавитации, вызывающей ненужные шумы и повреждения.
- ZH** 关于管道尺寸，请遵循我们的建议，管径太小或者弯头会形成气蚀，从而产生不必要的噪声和损坏

F11

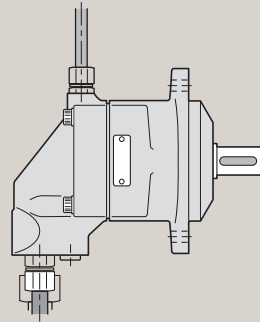
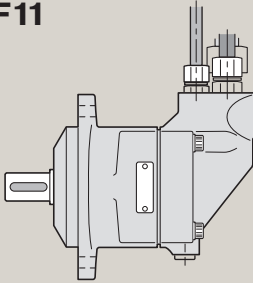

F10/F12

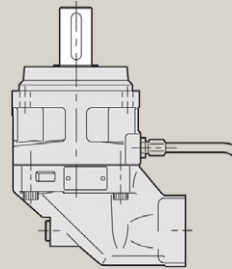
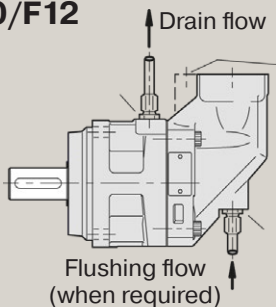

Spring  
loaded  
check  
valve

Drain  
flow

**SE** Anslut dränerledningen till den högst belägna dräneranslutningen på pumpen/motorn. Anslut om möjligt dränerledning direkt till tank för att undvika högt tryck i huset.

**UK** Use the drain connection, which is positioned uppermost on the pump/motor.

**DE** Benutzen Sie den Leckölanschluß, der je nach Einbaulage der Maschine am höchsten liegt.

**FR** Utiliser l'orifice de drain sa trouvant le plus haut sur le moteur la pompe.

**ES** Utilice la conexión de drenaje más alta según la posición de la bomba-motor.

**SF** Littä vuotoputki pumpun/moottorin ylämpään vuotoliitäntään. Mikäli mahdollista, liitä vuotoliitäntä suoraan säiliöön, jotta koneen pesässä et synnyisi korkea painetta.

**IT** Usare sempre il drenaggio più' alto conformemente al posizionamento della pompa.

**RU** Используйте присоединение дренажной линии, расположенное выше всего относительно места установки насоса / двигателя.

**ZH** 设计与连接泵/马达泄油管时要使用最上部的泄油口

- SE** Använd olja och filter enligt våra rekommendationer.
- UK** Use oil and filter as recommended by us.
- DE** Gebrauchen Sie das von uns empfohlene Öl und den von uns vorgeschlagenen Filter.
- FR** Employer une huile et un filtre conformes à nos recommandations.
- ES** Utilice aceites Y filtros de acuerdo con nuestras recomendaciones.
- SF** Käytä suosituksemme mukaista öljyä ja suodatinta.
- IT** Usare l'olio e i filtri da noi raccomandati.
- RU** Используйте масло и фильтр, которые рекомендованы нами.
- ZH** 请使用我们推荐的液压油与过滤
- SE** Rengör hydraulsystemet noga innan olja påfyllles.
- UK** Carefully clean the hydraulic system before the system is filled with oil.
- DE** Säubern Sie vor Einfüllung des Öls sorgfältig das System.
- FR** Nettoyer soigneusement le système avant de la remplir d'huile.
- ES** Limpie minuciosamente el sistema antes de llenarlo de aceite.
- SF** Puhdista hydraulijärjestelmä huolellisesti ennen öljyllä täyttämistä.
- IT** Si raccomanda la massima pulizia, specialmente nei raccocchi a nel cambio dell'olio.
- RU** Выполните тщательную очистку гидравлической системы, прежде чем заполнять ее маслом.
- ZH** 在系统加油之前，请确保整个液压系统干净

- SE** Fyll huset med olja före start.
- UK** Fill the casing with oil before start up.
- DE** Füllen Sie vor Beginn das Gehäuse mit Öl.
- FR** Remplir la carter de ta pompe ou du moteur avant la miss en route.
- ES** Liene le carcasa de aceite antes de ta puesta en marcha.
- SF** Täytä pesä öljyllä ennen käynnistystä.
- IT** Prima detta massa In funzione riempire d'olio la carcassa-pompa.
- RU** Заполните корпус маслом перед началом работы.
- ZH** 启动前，壳体装满油

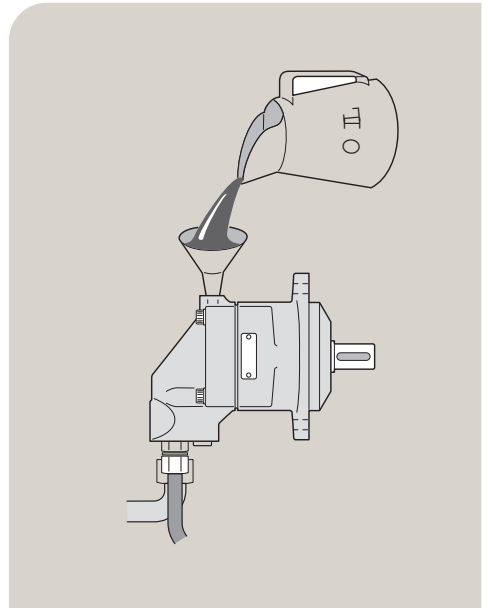





## **Position notification regarding Machinery Directive 2006/42/EC:**

Products made by the Pump & Motor Division Europe (PMDE) of Parker Hannifin are excluded from the scope of the machinery directive following the “Cetop” Position Paper on the implementation of the Machinery Directive 2006/42/EC in the Fluid Power Industry.

All PMDE products are designed and manufactured considering the basic as well as the proven safety principles according to:

- ISO 13849-1:2015
- SS-EN ISO 4413:2010

so that the machines in which the products are incorporated meet the essential health and safety requirements.

Confirmations for components to be proven component, e. g. for validation of hydraulic systems, can only be provided after an analysis of the specific application, as the fact to be a proven component mainly depends on the specific application.

### **Dr. Hans Haas**

General Manger

Pump & Motor Division Europe



## **WARNING – USER RESPONSIBILITY**

FAILURE OR IMPROPER SELECTION OR IMPROPER USE OF THE PRODUCTS DESCRIBED HEREIN OR RELATED ITEMS CAN CAUSE DEATH, PERSONAL INJURY AND PROPERTY DAMAGE.

This document and other information from Parker-Hannifin Corporation, its subsidiaries and authorized distributors provide product or system options for further investigation by users having technical expertise.

The user, through its own analysis and testing, is solely responsible for making the final selection of the system and components and assuring that all performance, endurance, maintenance, safety and warning requirements of the application are met. The user must analyze all aspects of the application, follow applicable industry standards, and follow the information concerning the product in the current product catalogue and in any other materials provided from Parker or its subsidiaries or authorized distributors.

To the extent that Parker or its subsidiaries or authorized distributors provide component or system options based upon data or specifications provided by the user, the user is responsible for determining that such data and specifications are suitable and sufficient for all applications and reasonably foreseeable uses of the components or systems.

## **Offer of Sale**

Please contact your Parker representation for a detailed "Offer of Sale".

### **Parker Hannifin Manufacturing Sweden AB**

Pump & Motor Division Europe

Flygmotorvägen 2

461 82 Trollhättan

Sweden

Tel. +46 (0)520 40 45 00

[www.parker.com/pmde](http://www.parker.com/pmde)

MSG30-8205-INST/EU

Art. No 3793839-06

© Copyright 2021

All rights reserved

