

2/2 NC

1/4" → 1"

Pag. 11.4

Ex

Serie X3F

Coils & Connectors



30 mm

Serie C

Pag. 19.5

C RU US
CSA C22.2



30 mm

Serie D

Pag. 19.6

C RU US
CSA C22.2



36 mm

Serie E

Pag. 19.7

C RU US
CSA C22.2



Connectors

Pag. 19.9 / 19.10

C RU US
CSA C22.2

ELETTROVALVOLE A MEMBRANA GUIDATA IN ACCIAIO INOX 316L

GUIDED DIAPHRAGM SOLENOID VALVES IN STAINLESS STEEL 316L

GEFÜHRTE MEMBRAN-MAGNETVENTILE MIT EDELSTAHL 316L

ÉLECTROVANNES À MEMBRANE GUIDÉE EN ACIER INOX 316L

ELECTROVALVULAS DE MEMBRANA GUIADA EN ACERO INOX 316L

ELETROVÁLVULAS DE MEMBRANA GUIADA EM AÇO INOX 316L

AISI 316L

II 2 G/D Ex h

C US
CSA C22.2

New

$\Delta P = 0$ bar

Long Life

Heavy Duty



Le elettrovalvole serie X3F – a membrana guidata con corpo filettato in acciaio inox 316L – combinano i principi di funzionamento delle valvole ad azionamento diretto e servo-azionate offrendo prestazioni uniche.

Le caratteristiche costruttive consentono a queste valvole di lavorare in condizioni gravose e con vita utile 5 volte superiore alle tradizionali elettrovalvole, garantendo prestazioni durature nel tempo.

L'apertura parziale è assicurata anche con $\Delta P = 0$ bar, tuttavia per un'apertura totale è necessario un $\Delta P > 0$ bar.

Principali vantaggi

- Connessioni da 1/4" a 1"
- Orifici dal \varnothing 10 mm al \varnothing 25 mm
- Pressioni di lavoro fino a 25 bar
- $\Delta P = 0$ bar
- Utilizzo in condizioni gravose
- Contatto con fluidi aggressivi e corrosivi
- Grado di protezione IP67 con connettore e kit antiumidità

Applicazioni

- Acqua, Oli, Liquidi neutri e corrosivi
- Autolavaggi, Sistemi di lavaggio
- Processi industriali, Scarico serbatoi
- Aria, Gas inerti e aggressivi
- Ossigeno, Vapore, Medicale, Sterilizzatori
- Industria Chimica e Petrochimica

The X3F series solenoid valves – guided diaphragm with 316L stainless steel threaded body – combine the operating principles of direct acting and servo-assisted valves, by offering unique performance.

The construction features allow these valves to work in harsh conditions and with a useful life 5 times higher than traditional solenoid valves, guaranteeing long-lasting performance.

Partial opening is ensured also with $\Delta P = 0$ bar, however for full opening $\Delta P > 0$ bar is required.

Main advantages

- Connections from 1/4" to 1"
- Orifices from \varnothing 10 mm up to \varnothing 25 mm
- Working pressures up to 25 bar
- $\Delta P = 0$ bar
- Use in harsh conditions
- Contact with aggressive and corrosive fluids
- IP67 protection degree with connector and anti-humidity kit

Applications

- Water, Oils, Neutral and corrosive liquids
- Car washes, Washing systems
- Industrial processes, Tank draining
- Air, Inert and aggressive gases
- Oxygen, Steam, Medical, Sterilizers
- Chemical and Petrochemical industry

Die Membran-Magnetventile der Serie X3F - mit Gewindekörper aus Edelstahl (316L) - vereinen die Funktionsprinzipien von direktwirkenden und vorgesteuerten Ventilen und bieten eine einzigartige Leistung.

Die Konstruktionsmerkmale ermöglichen den Einsatz dieser Ventile unter rauen Bedingungen und haben eine 5-mal höhere Lebensdauer als herkömmlichen Magnetventilen, was lange Betriebszeiten gewährleistet.

Auch ohne Differenzdruck ($\Delta P = 0$ bar) ist eine Teilweise Öffnung gewährleistet, für eine vollständige Öffnung ist jedoch ein Differenzdruck $\Delta P > 0$ bar erforderlich.

Vorteile

- Anschlüsse von 1/4" bis 1"
- Öffnungen von \varnothing 10 mm bis zu \varnothing 25 mm
- Betriebsdruck bis zu 25 bar
- $\Delta P = 0$ bar
- Einsatz unter rauen Bedingungen
- Kontakt mit aggressiven und korrosiven Fluiden
- IP67 Schutz mit Anschlussstück und Feuchtigkeitsschutz-Kit

Einsatzbereiche

- Wasser, Öle, neutrale und ätzende Flüssigkeiten
- Autowaschanlagen, Waschanlagen
- Industrielle Prozesse, Tankentleerung
- Luft, inerte und aggressive Gase
- Sauerstoff, Dampf, Medizin, Sterilisatoren
- Chemische und petrochemische Industrie

Les électrovannes de la série X3F - membrane guidée avec corps fileté en acier inoxydable 316L - combinent les principes de fonctionnement des vannes à commande directe et servo-assistées, en offrant des performances uniques.

Les caractéristiques de construction permettent à ces électrovannes de fonctionner dans des conditions difficiles et avec une durée de vie 5 fois supérieure aux électrovannes traditionnelles, garantissant des performances durables.

L'ouverture partielle est également assurée avec $\Delta P = 0$ bar, mais pour une ouverture complète, $\Delta P > 0$ bar est nécessaire.

Principaux avantages

- Connexions de 1/4" à 1"
- Orifices de \varnothing 10 mm à \varnothing 25 mm
- Pression jusqu'à 25 bar
- $\Delta P = 0$ bar
- Utilisation dans des conditions difficiles
- Contact avec des fluides agressifs et corrosifs
- Degré de protection IP67 avec connecteur et kit anti-humidité

Applications

- Eau, Huiles, Liquides neutres et corrosifs
- Lavage-autos, Systèmes de lavage
- Process industriels, Purge de réservoir
- Air, Gaz inertes et agressifs
- Oxygène, Vapeur, Médical, Stérilisateurs
- Industrie chimique et pétrochimique

Las electroválvulas de la serie X3F (membrana guiada con cuerpo roscado de acero inoxidable 316L) combinan los principios de funcionamiento de las válvulas de acción directa y servoasistidas, ofreciendo un rendimiento único.

Las características de construcción permiten que estas válvulas trabajen en condiciones duras y con una vida útil 5 veces superior a las electroválvulas tradicionales, garantizando un rendimiento duradero.

La apertura parcial también está garantizada con $\Delta P = 0$ bar, sin embargo, para la apertura total se requiere $\Delta P > 0$ bar.

Principales ventajas

- Conexiones de 1/4" a 1"
- Orificios desde \varnothing 10 mm hasta \varnothing 25 mm
- Presiones de trabajo hasta 25 bar
- $\Delta P = 0$ bar
- Uso en condiciones duras
- Contacto con fluidos agresivos y corrosivos
- Grado de protección IP67 con conector y kit antihumedad

Aplicaciones

- Agua, Aceites, Líquidos neutros y corrosivos
- Lavado de autos, Sistemas de lavado
- Procesos industriales, Vaciado de tanques
- Aire, Gases inertes y agresivos
- Oxígeno, Vapor, Médico, Esterilizadores
- Industria química y petroquímica

As válvulas solenóide da série X3F – diafragma guiado com corpo roscado em aço inoxidável 316L – combinam os princípios operacionais de válvulas de ação direta e servo-assistidas, oferecendo um desempenho sem igual.

As características construtivas permitem que essas válvulas trabalhem em condições adversas e com uma vida útil 5 vezes maior que as válvulas solenoides tradicionais, garantindo desempenho duradouro.

A abertura parcial também é assegurada com $\Delta P = 0$ bar, porém para abertura total é necessário $\Delta P > 0$ bar.

Principais vantagens

- Conexões de 1/4" a 1"
- Orifícios de \varnothing 10 mm até \varnothing 25 mm
- Pressões de trabalho até 25 bar
- $\Delta P = 0$ bar
- Uso em condições adversas
- Contato com fluidos agressivos e corrosivos
- Grau de proteção IP67 com conector e kit anti-umidade

Aplicações

- Água, óleos, líquidos neutros e corrosivos
- Lavagens de carros, Sistemas de limpeza e lavagem em geral
- Processos industriais, Drenagem de tanques
- Ar, gases inertes e agressivos
- Oxigênio, Vapor, Médico, Esterilizadores
- Indústria química e petroquímica



Caratteristiche generali - X3F IT - Posizione di montaggio consigliata orizzontale - Kit operatore Ø 13 mm - Certificazione valvole: ATEX II 2G/D Ex h - Bobine: classe H - - CSA C22.2	General features - X3F GB - Recommended horizontal mounting position - Operator kit Ø 13 mm - ATEX II 2G/D Ex h certification - Coils: Class H - - CSA C22.2	Eigenschaften - X3F DE - Horizontale Einbaulage empfohlen - Bausatz Ø 13 mm - ATEX II 2G/D Ex h zulassung - Spulenkategorie H - - CSA C22.2
Caractéristiques générales - X3F FR - Position de montage horizontale recommandée - Kit Pilote Ø 13 mm - Certification ATEX II 2G/D Ex h - Bobine: classe H - - CSA C22.2	Características generales - X3F ES - Posición de montaje recomendada horizontal - Kit operador Ø 13 mm - Certificación ATEX II 2G/D Ex h - Bobinas: clase H - - CSA C22.2	Características gerais - X3F PT - Posição de montagem aconselhada horizontal - Kit do operador Ø 13 mm - Certificação ATEX II 2G/D Ex h - Bobinas: classe H - - CSA C22.2



Tabella dei codici di ordinazione

Ordering codes

Bestellschlüssel

Composition de la référence de commande

Tabla para definición de código

Tabela de código de compra

SERIE	Connessione Port size Masse Dimension Tamaño Tamanho	Funzione Functions Funktion Fonctions Función Funções	Orifizio Orifice Dn Passage Orifício Orifício	Materiale guarnizioni Sealing materials Dichtungswerkstoffe Matériaux des joints Material juntas Material das vedações	Versione Version Ausführung Version Versión Versão	Filettatura Thread Gewinde Filetage Rosca Rosca
-------	---	--	--	---	---	--

X	3	F	0	3	1	1	0	N	0	
	03 = 1/4"				1 = 2/2 NC	1 = 10 mm		N = NBR	0 = Standard	= Gas
	04 = 3/8"					14 = 14 mm		E = EPDM		
	05 = 1/2"					18 = 18 mm		V = FKM		
	07 = 3/4"					25 = 25 mm				
	09 = 1"									

BOBINE: SERIE C, D, E COILS: SERIES C, D, E SPULEN: SERIES C, D, E BOBINES: SÉRIES C, D, E BOBINAS: SERIES C, D, E BOBINAS: SÉRIES C, D, E	PAG: 19.5 / 19.6 / 19.7 PAG: 19.5 / 19.6 / 19.7 PAG: 19.5 / 19.6 / 19.7 PAG: 19.5 / 19.6 / 19.7 PAG: 19.5 / 19.6 / 19.7 PAG: 19.5 / 19.6 / 19.7	CONNETTORI CONNECTORS STECKER CONNECTEURS CONECTORES CONECTORES	PAG: 19.10 PAG: 19.10 PAG: 19.10 PAG: 19.10 PAG: 19.10 PAG: 19.10
--	---	---	---

SERIE X3F

ELETTROVALVOLE A MEMBRANA GUIDATA - $\Delta P = 0$ bar (per apertura completa membrana $\Delta P > 0$ bar)

GUIDED DIAPHRAGM SOLENOID VALVES - $\Delta P = 0$ bar (complete diaphragm opening $\Delta P > 0$ bar)

GEFÜHRTE MEMBRAN-MAGNETVENTILE - $\Delta P = 0$ bar (zum vollständige Membranöffnung $\Delta p > 0$ bar)

ÉLECTROVANNES À MEMBRANE GUIDÉE - $\Delta P = 0$ bar (pour diaphragme ouverture complete $\Delta p > 0$ bar)

ELECTROVALVULAS DE MEMBRANA GUIADA - $\Delta P = 0$ bar (para apertura completa de la membrana $\Delta p > 0$ bar)

ELETRÓVALVULAS DE MEMBRANA GUIADA - $\Delta P = 0$ bar (para abertura completa da membrana $\Delta p > 0$ bar)

2/2 NC

1/4" → 1"

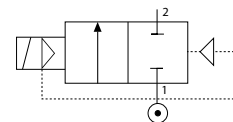

$\Delta P = 0$ bar

Long Life

Heavy Duty



Anello di sfasamento argentato su richiesta
Silver-plated shading ring on request
Versilberter Schattierungsring auf anfrage
Anneau d'ombrage argentée sur demande
Anillo de sombreado plateado bajo pedido
Anel de sombreamento banhado a prata sob pedido

Materiali e Componenti	IT	Materials and Components	GB	Materialien und Komponenten	DE
1 Corpo: Acciaio Inox AISI 316L		1 Body: Stainless steel AISI 316L		1 Körper: Edelstahl AISI 316L	
2 Tenute: NBR - EPDM - FKM		2 Seals: NBR - EPDM - FKM		2 Dichtung: NBR - EPDM - FKM	
3 Tubo guida: Acciaio Inox		3 Armature tube: Stainless steel		3 Führungsrohr: Edelstahl	
4 Nucleo fisso e mobile: Acciaio Inox AISI 430FR		4 Fixed and mobile core: Stainless steel AISI 430FR		4 Kern: Edelstahl AISI 430FR	
5 Molle: Acciaio Inox		5 Springs: Stainless steel		5 Feder: Edelstahl	
6 Anello di sfasamento: Rame		6 Shading ring: Copper		6 Schattierung Ring: Kupfer	

Matériaux et Composants	FR	Materiales y componentes	ES	Materialis e Componentes	PT
1 Corps: Acier inox AISI 316L		1 Cuerpo: Acero inox AISI 316L		1 Corpo: Aço-inox AISI 316L	
2 Joints: NBR - EPDM - FKM		2 Juntas: NBR - EPDM - FKM		2 Vedações: NBR - EPDM - FKM	
3 Tube de pilotage: Acier inox		3 Tubo guía: Acero inox		3 Tubo Guia: Aço-inox	
4 Noyau: Acier inox AISI 430FR		4 Núcleo fijo y móvil: Acero inox AISI 430FR		4 Núcleo fixo e móvel I: Aço-inox AISI 430FR	
5 Ressort: Acier inox		5 Muelle: Acero inox		5 Mola: Aço-inox	
6 Anneaux d'ombrage : cuivre		6 Anillo de sombreado: Cobre		6 Anel de sombreamento: Cobre	



Pressione massima ammissibile
Maximum allowable pressure
Max. Betriebsdruck
Pression de service max.
Presión máxima admisible
Pressão máxima admissível

25 bar





Tabella compatibilità e materiali
Compatibility and materials table
Beständigkeitsübersicht
Tableau de compatibilité des matériaux
Tabla de compatibilidad de materiales
Tabela de compatibilidade química

Pag. 0.21 - 0.22



Temperatura ambiente con bobine in classe H
Room temperature with coil class H
Raumtemperatur, mit Spule der Klasse H
Température ambiante, avec bobine classe H
Temperatura ambiente con bobina clase H
Temperatura ambiente com bobina de classe H

- 10 °C
+ 80 °C

OPZIONI SU RICHIESTA - OPTIONS ON REQUEST - OPTIONEN AUF ANFRAGE - OPTIONS SUR DEMANDE - OPCIONES BAJO PEDIDO - OPÇÕES SOB ENCOMENDA
Anello di sfasamento argentato - Silver-plated shading ring - Versilberter Schattierungsring Anneau d'ombrage argentée - Anillo de sombreado plateado - Anel de sombreamento banhado a prata
Versione idonea per utilizzo con ossigeno industriale - Version suitable for use with industrial oxygen - Version für industrie sauerstoff Version adaptée à une utilisation avec de l'oxygène industriel - Versión idónea para el uso con oxígeno industrial - Versão adequada para utilização com oxigênio industrial

Code	Materiale tenute Sealing materials Dichtungswerkstoffe Matériau joint Material juntas Material das vedações	Connessioni Port size Verbindungen Connexions Conexiones Conexões	Ø Orifizio Ø Orifice Ø Dn Ø Passage Ø Orificio Ø Orificio	Viscosità Viscosity Viskosität Viscosité Viscosidad Viscosidade	Kv	Pressione differenziale (OPD) Differential pressure (OPD) Differenzdruck (OPD) Pression différentielle (OPD) Presión diferencial (OPD) Pressão diferencial (OPD)			Potenza Power Leistung Puissance Potencia Potência		Bobine Coils Spulen Bobines Bobinas Bobinas	
						Min	Max DC	Max AC	DC W	AC VA	Size mm	Serie C - pag. 19.5 D - pag. 19.6 E - pag. 19.7
		ISO 228	mm	cSt	m ³ /h	Bar						
X3F 03 1 10 _0	N = NBR -10°C +90°C	1/4"	10	25	1.58	0	-	18	-	14	30	C - SOL20
6							20	14	21	30	D - SOL20	
16							25	22	31	36	E - SOL21	
X3F 04 1 14 _0		3/8"	14	25	2.73	0	-	18	-	14	30	C - SOL20
6							20	14	21	30	D - SOL20	
X3F 05 1 14 _0	V = FKM -10°C +140°C	1/2"	14	25	2.75	0	-	18	-	14	30	C - SOL20
6							20	14	21	30	D - SOL20	
16							25	22	31	36	E - SOL21	
X3F 07 1 18 _0	E = EPDM -10°C +140°C	3/4"	18	25	4.08	0	-	18	-	14	30	C - SOL20
6							20	14	21	30	D - SOL20	
16							25	22	31	36	E - SOL21	
X3F 09 1 25 _0	1"	25	25	6.63	0	-	16	-	14	30	C - SOL20	
4						20	14	21	30	D - SOL20		
12						25	22	31	36	E - SOL21		

① **Selezionare tenuta** - Select seal material - Wählen Sie das Dichtungsmaterial aus - Sélectionner matériau d'étanchéité - Seleccionar material sellado - Seleccionar material de vedação

EPDM - P max= 2.5 bar: Con vapore - With steam - Mit dampf - Avec vapeur - Con vapor - Com vapor

Bobina non inclusa - Coil not included - Magnetspulen separat - Bobines non incluse - Bobina no incluida - Bobinas não incluidas

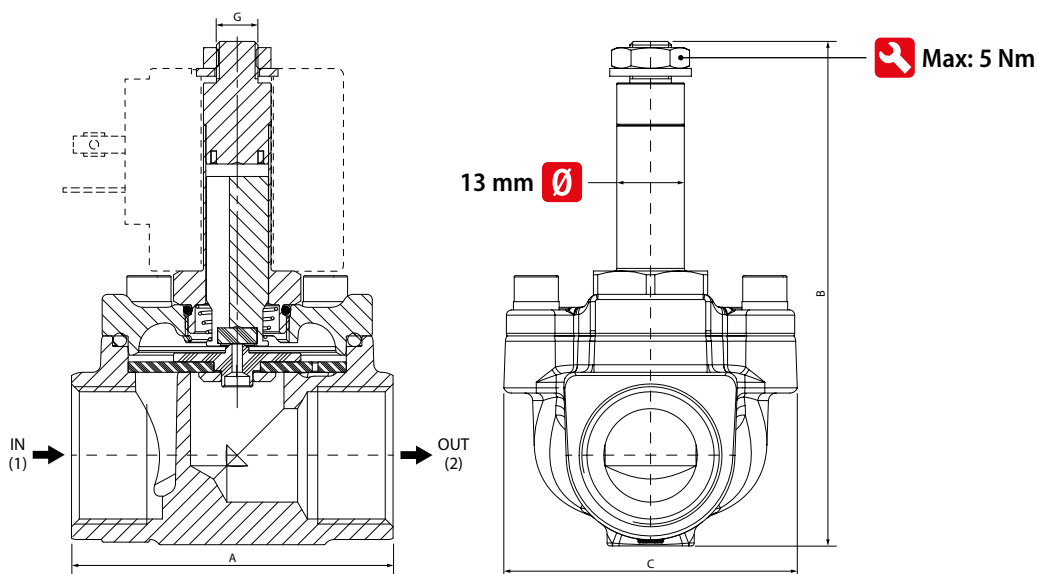

Size	A	B	C	G
1/4"	44	84	40	M8 x 1
3/8"	52	91.5	46.5	M8 x 1
1/2"	52	91.5	46.5	M8 x 1
3/4"	62	97	56.5	M8 x 1
1"	72.5	105.5	66	M8 x 1

22 mm



Serie A
Pag. 19.2

UL
CSA C22.2

30 mm



Serie B
Pag. 19.3

UL
CSA C22.2

30 mm



Serie X
Pag. 19.4

Ex

30 mm



Serie C
Pag. 19.5

UL
CSA C22.2

30 mm



Serie D
Pag. 19.6

UL
CSA C22.2

36 mm



Serie E
Pag. 19.7

UL
CSA C22.2

50 mm



Serie Y
Pag. 19.8

Ex

Connectors

Coils & Connectors



Connectors
Pag. 19.9 / 19.10

UL
CSA C22.2

Aignep si riserva il diritto di variare modelli e ingombri senza preavviso - Aignep reserves the right to vary models and dimensions without notice - Aignep behält sich das Recht vor, Daten ohne Ankündigung zu ändern
Aignep se reserva el derecho de modificar modelos y dimensiones sin previo aviso - Aignep se réserve le droit de modifier les données sans préavis

BOBINE E CONNETTORI

COILS AND CONNECTORS

SPULEN UND STECKER

BOBINES ET CONNECTEURS

BOBINAS Y CONECTORES

BOBINAS E CONECTORES



Coils & Connectors

Aignep offre un'ampia gamma di bobine e connettori standard (su richiesta anche in configurazione speciale) per soddisfare qualsiasi tipo di esigenza applicativa.

Le bobine sono disponibili in diverse taglie, con servizio continuo ED 100%, differenti potenze e nelle tensioni standard 12 / 24 VDC e 24 / 110 / 220 VAC; l'isolamento in classe H e la certificazione UL Recognized sono garantiti su tutte le bobine.

Sono altresì disponibili le versioni certificate ATEX per installazione in ambienti potenzialmente esplosivi (Ex mb e Ex d/tb).

I connettori sono disponibili con grado di protezione IP67 e nelle versioni standard con involucro nero o trasparente con led di segnalazione, oltre alla versione certificata UL Recognized.

Aignep offers a wide range of standard coils and connectors (on request also in special configuration) to satisfy any type of application requirement.

The coils are available in different sizes, with continuous duty ED 100%, different powers and in the standard voltages 12 / 24 VDC and 24 / 110 / 220 VAC; class H insulation and UL Recognized certification are guaranteed on all coils.

ATEX certified versions are also available for installation in potentially explosive environments (Ex mb and Ex d/tb).

The connectors are available with IP67 protection degree and in the standard versions with black case or transparent case with LED, in addition to the UL Recognized certified version.

Aignep bietet eine breite Palette von Standardspulen und Steckern (auf Anfrage auch in Sonderkonfiguration) an, um jede Art von Anwendungsanforderung zu erfüllen.

Die Spulen sind in verschiedenen Größen, mit Dauerbetrieb ED 100%, in verschiedenen Leistungen und in den Standardspannungen 12 / 24 VDC und 24 / 110 / 220 VAC erhältlich. Alle Magnetspulen haben die Isolierklasse H und haben eine UL-Zertifizierung.

ATEX-zertifizierte Versionen für die Installation in explosionsgefährdeten Umgebungen (Ex mb und Ex d/tb) sind ebenfalls erhältlich.

Die Stecker sind in der Schutzart IP67 und in den Standardversionen mit schwarzem Gehäuse oder transparentem Gehäuse mit LED erhältlich, zusätzlich zur UL-zertifizierten Version.

Aignep propose une large gamme de bobines et de connecteurs standards (sur demande également en configuration spéciale) pour répondre à tout type d'exigence d'application.

Les bobines sont disponibles en différentes tailles, avec service continu ED 100%, différentes puissances et dans les tensions standard 12 / 24 VDC et 24 / 110 / 220 VAC; l'isolation de classe H et la certification reconnue UL sont garanties sur toutes les bobines.

Des versions certifiées ATEX sont également disponibles pour une installation dans des environnements potentiellement explosifs (Ex mb et Ex d/tb).

Les connecteurs sont disponibles avec un degré de protection IP67 et dans les versions standard avec boîtier noir ou boîtier transparent avec LED, en plus de la version certifiée UL.

Aignep ofrece una amplia gama de bobinas y conectores estándar (bajo pedido también en configuración especial) para satisfacer cualquier tipo de requisito de aplicación.

Las bobinas están disponibles en diferentes tamaños, con servicio continuo ED 100%, diferentes potencias y en los voltajes estándar 12/24 VDC y 24/110/220 VAC; El aislamiento de clase H y la certificación reconocida por UL están garantizados en todas las bobinas.

Las versiones certificadas ATEX también están disponibles para su instalación en entornos potencialmente explosivos (Ex mb y Ex d/tb).

Los conectores están disponibles con grado de protección IP67 en las versiones estándar con caja negra o caja transparente con LED, además de la versión certificada UL Recognized.

A Aignep oferece uma ampla gama de bobinas e conectores padrão (sob encomenda também em configurações especiais) para satisfazer qualquer tipo de exigência de aplicação.

As bobinas estão disponíveis em diversos tamanhos, com regime contínuo ED 100%, diferentes potências e nas tensões padrão 12 / 24 VDC e 24 / 110 / 220 VAC; classe de isolamento H e certificação UL reconhecida para todas as bobinas.

Versões com certificação ATEX também estão disponíveis para instalação em ambientes potencialmente explosivos (Ex mb e Ex d/tb).

Os conectores estão disponíveis com grau de proteção IP67 e nas versões padrão com caixa preta ou caixa transparente com LED, além da versão certificada UL Recognized.



Aignep
SRL - Via...
CE...
...
...
...



Aignep
SRL - Via...
CE...
...
...
...



Aignep
SRL - Via...
CE...
...
...
...

SERIE A

BOBINA

COIL
SPULE
BOBINE
BOBINA
SOLENOÏDE



22 mm

10 mm

ED 100%

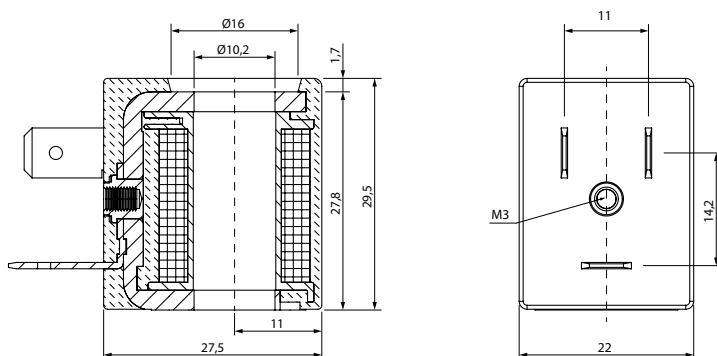

UL 429 & CSA C22.2 NO. 139-13

Riferimento <i>Reference</i> <i>Referenz</i> <i>Référence</i> <i>Referència</i> <i>Referência</i>	Codice <i>Code</i> <i>Code</i> <i>Code</i> <i>Código</i> <i>Código</i>	Tensione <i>Voltage</i> <i>Leistung</i> <i>Tension</i> <i>Tensión</i> <i>Tensão</i>	Potenza <i>Power</i> <i>Leistung</i> <i>Puissance</i> <i>Potencia</i> <i>Potência</i>	Tolleranze di tensione <i>Voltage tolerance</i> <i>Spannungstoleranz</i> <i>Tolérance de la tension</i> <i>Tolerancia de tensión</i> <i>Tolerância de tensão</i>	Temperatura ambiente <i>Ambient temperature</i> <i>Umgebungstemperatur</i> <i>Température ambiante</i> <i>Temperatura ambiente</i> <i>Temperatura Ambiente</i>	
					Min	Max
AA	SOL10012C4000	12V DC	6.5 W	±10 %	-10 °C	+80 °C
AB	SOL10024C4000	24V DC	6.5 W	±10 %	-10 °C	+80 °C
A1	SOL10024A8000	24V AC / 50-60 Hz	7.5 VA	±10 %	-10 °C	+80 °C
A2	SOL10110A8000	110V AC / 50-60 Hz	7.5 VA	±10 %	-10 °C	+80 °C
A3	SOL10220A8000	220V AC / 50-60 Hz	7.5 VA	±10 %	-10 °C	+80 °C

CLASSE DI ISOLAMENTO
INSULATION CLASS
ISOLIERSTOFFKLASSE
CLASSE D'ISOLATION
CLASE DE AISLAMIENTO
CLASSE DE ISOLAMENTO

H
EN 60085

MATERIALE INCAPSULAMENTO
ENCAPSULATION MATERIAL
VERGUSSTMASSE
MATERIAUX EXTÉRIEUR
MATERIAL DE ENCAPSULAMIENTO
MATERIAL DE ENCAPSULAMENTO

RYNITE®

CONNESSIONI ELETTRICHE
ELECTRICAL CONNECTIONS
ELEKTRISCHE ANSCHLÜSSE
CONNEXIONS ELECTRIQUES
CONEXIÓN ELÉCTRICA
CONEXÕES ELÉTRICAS

FORM B
EN 175301-803
(EX DIN 43650)

TEMPERATURA AMBIENTE
AMBIENT TEMPERATURE
UMGEBUNGSTEMPERATUR
TEMPÉRATURE AMBIANTE
TEMPERATURA AMBIENTE
TEMPERATURA AMBIENTE

-10 °C
+80 °C

GRADO DI PROTEZIONE
PROTECTION DEGREE
SCHUTZART
DEGRÉ DE PROTECTION
GRADO DE PROTECCIÓN
GRAU DE PROTEÇÃO

IP67
IEC 60529

Con connettore IP67
with connector IP67
Mit Stecker IP67
Avec connecteur IP67
Con conector IP67
Com conector IP67

OPZIONI
OPTIONS
OPTIONEN
OPTIONS
OPCIONES
OPÇÕES

Altre tensioni/potenze su richiesta
Other voltages/powers on request
Andere Spannungen/Leistungen auf Anfrage
Autres tensions/puissances sur demandes
Otras tensiones-potencia bajo pedido
Outras tensões/potências sob encomenda

SERIE B

BOBINA

COIL
SPULE
BOBINE
BOBINA
SOLENÓIDE



30 mm

10 mm

ED 100%

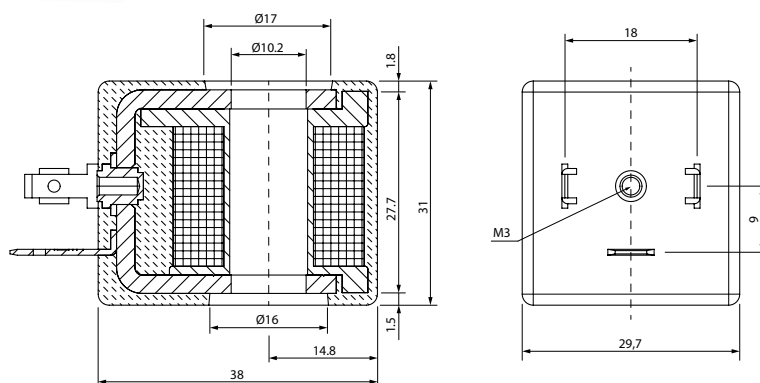

UL 429 & CSA C22.2 NO. 139-13

Riferimento Reference Referenz Référéce Referencia Referência	Codice Code Code Code Código Código	Tensione Voltage Leistung Tension Tensión Tensão	Potenza Function Leistung Puissance Potencia Potência	Tolleranze di tensione Voltage tolerance Spannungstoleranz Tolérance de la tension Tolerancia de tensión Tolerância de tensão	Temperatura ambiente Ambient temperature Umgebungstemperatur Température ambiante Temperatura ambiente Temperatura Ambiente	
					Min	Max
BA	SOL11012C5000	12V DC	8 W	±10 %	-10 °C	+80 °C
BB	SOL11024C5000	24V DC	8 W	±10 %	-10 °C	+80 °C
B1	SOL11024A9000	24V AC / 50-60 Hz	11 VA	±10 %	-10 °C	+80 °C
B2	SOL11110A9000	110V AC / 50-60 Hz	11 VA	±10 %	-10 °C	+80 °C
B3	SOL11220A9000	220V AC / 50-60 Hz	11 VA	±10 %	-10 °C	+80 °C

CLASSE DI ISOLAMENTO
INSULATION CLASS
ISOLIERSTOFFKLASSE
CLASSE D'ISOLATION
CLASE DE AISLAMIENTO
CLASSE DE ISOLAMENTO

H
EN 60085

MATERIALE INCAPSULAMENTO
ENCAPSULATION MATERIAL
VERGUSSTMASSE
MATERIAUX EXTÉRIEUR
MATERIAL DE ENCAPSULAMIENTO
MATERIAL DE ENCAPSULAMENTO

RYNITE®

CONNESSIONI ELETTRICHE
ELECTRICAL CONNECTIONS
ELEKTRISCHE ANSCHLÜSSE
CONNEXIONS ELECTRIQUES
CONEXIÓN ELÉCTRICA
CONEXÕES ELÉTRICAS

FORM A
EN 175301-803
(EX DIN 43650)

TEMPERATURA AMBIENTE
AMBIENT TEMPERATURE
UMGEBUNGSTEMPERATUR
TEMPÉRATURE AMBIANTE
TEMPERATURA AMBIENTE
TEMPERATURA AMBIENTE

-10 °C
+80 °C

GRADO DI PROTEZIONE
PROTECTION DEGREE
SCHUTZART
DEGRÉ DE PROTECTION
GRADO DE PROTECCIÓN
GRAU DE PROTEÇÃO

IP67
IEC 60529

Con connettore IP67
with connector IP67
Mit Stecker IP67
Avec connecteur IP67
Con conector IP67
Com conector IP67

OPZIONI
OPTIONS
OPTIONEN
OPTIONEN
OPCIONES
OPÇÕES

Altre tensioni/potenze su richiesta
Other voltages/powers on request
Andere Spannungen/Leistungen auf Anfrage
Autres tensions/puissances sur demandes
Otras tensiones-potencia bajo pedido
Outras tensões/potências sob encomenda

SERIE X

BOBINA

COIL
SPULE
BOBINE
BOBINA
SOLENÓIDE

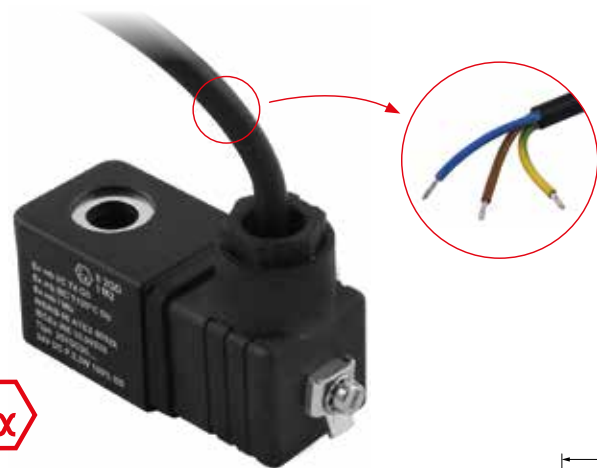

30 mm

10 mm

ED 100%



ATEX
II 2G Ex mb IIC T4 Gb
II 2D Ex mb IIIC T135°C Db
I M2 Ex mb I Mb
INERIS 06ATEX0002X

IECEX
Ex mb IIC T4 Gb
Ex mb IIIC T135°C Db
Ex mb I Mb
IECEX INE 15.0053X

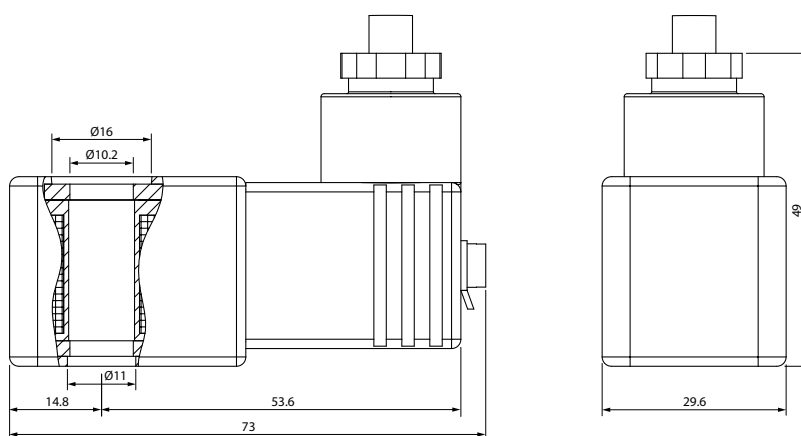

Riferimento <i>Reference Referenz Référence Referencia Referência</i>	Codice <i>Code Code Code Código Código</i>	Tensione <i>Voltage Leistung Tension Tensión Tensão</i>	Potenza <i>Power Leistung Puissance Potencia Potência</i>	Tolleranze di tensione <i>Voltage tolerance Spannungstoleranz Tolérance de la tension Tolerancia de tensión Tolerância de tensão</i>	Temperatura ambiente <i>Ambient temperature Umgebungstemperatur Température ambiante Temperatura ambiente Temperatura Ambiente</i>	
					Min	Max
XB	SOLX4024CE000	24V DC	5.3 W	±10 %	-20 °C	+40 °C
X1	SOLX4024AE000	24V AC / 50-60 Hz	5.3 W	±10 %	-20 °C	+40 °C
X2	SOLX4110AE000	110V AC / 50-60 Hz	5.3 W	±10 %	-20 °C	+40 °C
X3	SOLX4220AE000	230V AC / 50-60 Hz	5.3 W	±10 %	-20 °C	+40 °C

CLASSE DI ISOLAMENTO
CLASS OF ISOLATION
ISOLIERSTOFFKLASSE
CLASSE D'ISOLATION
CLASE DE AISLAMIENTO
CLASSE DE ISOLAMENTO

H
EN 60085

MATERIALE INCAPSULAMENTO
ENCAPSULATION MATERIAL
VERGUSSTMASSE
MATERIAUX EXTÉRIEUR
MATERIAL DE ENCAPSULAMIENTO
MATERIAL DE ENCAPSULAMENTO

POLYAMIDE

CONNESSIONI ELETTRICHE
ELECTRICAL CONNECTIONS
ELEKTRISCHE ANSCHLÜSSE
CONNEXIONS ELECTRIQUES
CONEXIÓN ELÉCTRICA
CONEXÕES ELÉTRICAS

3 Mt.
Cavo tripolare
Three-pole cable
3-adriges Kabel
Câble tripolaire
Cable tripolar
Cabo tripolar

GRADO DI PROTEZIONE
DEGREE OF PROTECTION
SCHUTZART
DEGRÉ DE PROTECTION
GRADO DE PROTECCIÓN
GRAU DE PROTEÇÃO

IP6_
IEC 60529
In base al cablaggio
According to wiring
Je nach Verdrahtung
Selon le câblage
Según el cableado
Acordo o cabeamento

CARATTERISTICHE
FEATURES
EIGENSCHAFTEN
CARACTÉRISTIQUES
CARACTERÍSTICA
CARACTERÍSTICAS

Fusibile interno
Internal fuse
Interne Sicherung
Fusible interne
Fusível interno

NORMATIVE ATEX
ATEX REGULATIONS
ATEX RICHTLINIEN
NORMATIVE ATEX
NORMATIVA ATEX
NORMATIVA ATEX

EN 60079-0
EN 60079-18

SERIE C

BOBINA

COIL
SPULE
BOBINE
BOBINA
SOLENÓIDE



30 mm

13 mm

ED 100%



UL 429 & CSA C22.2 NO. 139-13

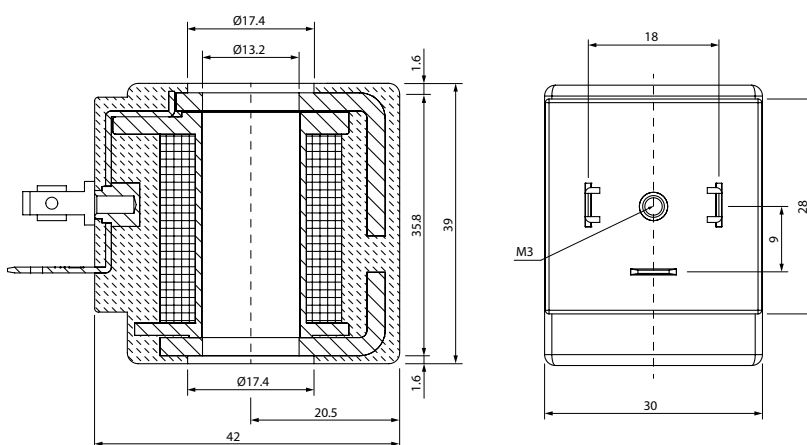

Riferimento Reference Referenz Référéce Referencia Referência	Codice Code Code Code Código Código	Tensione Voltage Leistung Tension Tensión Tensão	Potenza Function Leistung Puissance Potencia Potência	Tolleranze di tensione Voltage tolerance Spannungstoleranz Tolérance de la tension Tolerancia de tensión Tolerância de tensão	Temperatura ambiente Ambient temperature Umgebungstemperatur Température ambiante Temperatura ambiente Temperatura Ambiente	
					Min	Max
CA	SOL20012C5000	12V DC	8 W	±10 %	-10 °C	+80 °C
CB	SOL20024C5000	24V DC	8 W	±10 %	-10 °C	+80 °C
C1	SOL20024AA000	24V AC / 50-60 Hz	14 VA	±10 %	-10 °C	+80 °C
C2	SOL20110AA000	110V AC / 50-60 Hz	14 VA	±10 %	-10 °C	+80 °C
C3	SOL20220AA000	220V AC / 50-60 Hz	14 VA	±10 %	-10 °C	+80 °C

CLASSE DI ISOLAMENTO
CLASS OF ISOLATION
ISOLIERSTOFFKLASSE
CLASSE D'ISOLATION
CLASE DE AISLAMIENTO
CLASSE DE ISOLAMENTO

H
EN 60085

MATERIALE INCAPSULAMENTO
ENCAPSULATION MATERIAL
VERGÜSSMASSE
MATERIAUX EXTÉRIEUR
MATERIAL DE ENCAPSULAMIENTO
MATERIAL DE ENCAPSULAMENTO

RYNITE®

CONNESSIONI ELETTRICHE
ELECTRICAL CONNECTIONS
ELEKTRISCHE ANSCHLÜSSE
CONNEXIONS ELECTRIQUES
CONEXIÓN ELÉCTRICA
CONEXÕES ELÉTRICAS

FORM A
EN 175301-803
(EX DIN 43650)

TEMPERATURA AMBIENTE
AMBIENT TEMPERATURE
UMGEBUNGSTEMPERATUR
TEMPÉRATURE AMBIANTE
TEMPERATURA AMBIENTE
TEMPERATURA AMBIENTE

-10 °C
+80 °C

GRADO DI PROTEZIONE
PROTECTION DEGREE
SCHUTZART
DEGRÉ DE PROTECTION
GRADO DE PROTECCIÓN
GRAU DE PROTEÇÃO

IP67
IEC 60529
Con connettore IP67
with connector IP67
Mit Stecker IP67
Avec connecteur IP67
Con conector IP67
Com conector IP67

OPZIONI
OPTIONS
OPTIONEN
OPÇÕES

Altre tensioni/potenze su richiesta
Other voltages/powers on request
Andere Spannungen/Leistungen auf Anfrage
Autres tensions/puissances sur demandes
Otras tensiones-potencia bajo pedido
Outras tensões/potências sob encomenda

SERIE D

BOBINA

COIL
SPULE
BOBINE
BOBINA
SOLENOÏDE



30 mm

13 mm

ED 100%

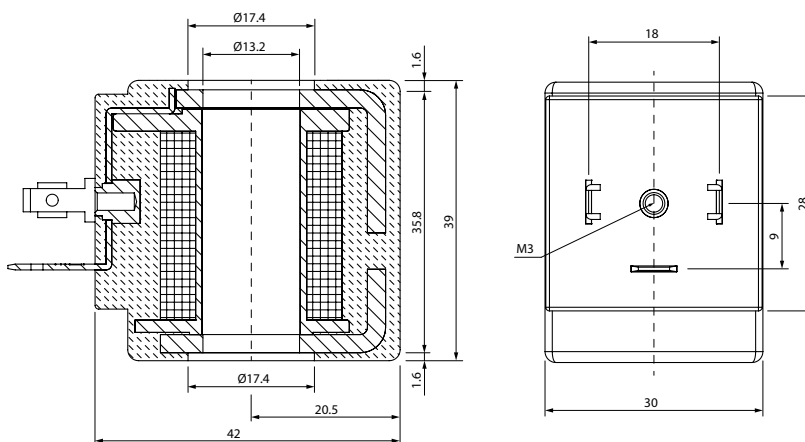

UL 429 & CSA C22.2 NO. 139-13

Riferimento <i>Reference</i> <i>Referenz</i> <i>Référence</i> <i>Referencia</i> <i>Referência</i>	Codice <i>Code</i> <i>Code</i> <i>Code</i> <i>Código</i> <i>Código</i>	Tensione <i>Voltage</i> <i>Leistung</i> <i>Tension</i> <i>Tensión</i> <i>Tensão</i>	Potenza <i>Function</i> <i>Leistung</i> <i>Puissance</i> <i>Potencia</i> <i>Potência</i>	Tolleranze di tensione <i>Voltage tolerance</i> <i>Spannungstoleranz</i> <i>Tolérance de la tension</i> <i>Tolerancia de tensión</i> <i>Tolerância de tensão</i>	Temperatura ambiente <i>Ambient temperature</i> <i>Umgebungstemperatur</i> <i>Température ambiante</i> <i>Temperatura ambiente</i> <i>Temperatura Ambiente</i>	
					Min	Max
DA	SOL20012C6000	12V DC	14 W	±10 %	-10 °C	+80 °C
DB	SOL20024C6000	24V DC	14 W	±10 %	-10 °C	+80 °C
D1	SOL20024AB000	24V AC / 50-60 Hz	21 VA	±10 %	-10 °C	+80 °C
D2	SOL20110AB000	110V AC / 50-60 Hz	21 VA	±10 %	-10 °C	+80 °C
D3	SOL20220AB000	220V AC / 50-60 Hz	21 VA	±10 %	-10 °C	+80 °C

CLASSE DI ISOLAMENTO

INSULATION CLASS
ISOLIERSTOFFKLASSE
CLASSE D'ISOLATION
CLASE DE AISLAMIENTO
CLASSE DE ISOLAMENTO

H
EN 60085

MATERIALE INCAPSULAMENTO

ENCAPSULATION MATERIAL
VERGUSSTMASSE
MATERIAUX EXTÉRIEUR
MATERIAL DE ENCAPSULAMIENTO
MATERIAL DE ENCAPSULAMENTO

RYNITE®

CONNESSIONI ELETTRICHE

ELECTRICAL CONNECTIONS
ELEKTRISCHE ANSCHLÜSSE
CONNEXIONS ELECTRIQUES
CONEXIÓN ELÉCTRICA
CONEXÕES ELÉTRICAS

FORM A
EN 175301-803
(EX DIN 43650)

TEMPERATURA AMBIENTE

AMBIENT TEMPERATURE
UMGEBUNGSTEMPERATUR
TEMPÉRATURE AMBIANTE
TEMPERATURA AMBIENTE
TEMPERATURA AMBIENTE

-10 °C
+80 °C

GRADO DI PROTEZIONE

PROTECTION DEGREE
SCHUTZART
DEGRÉ DE PROTECTION
GRADO DE PROTECCIÓN
GRAU DE PROTEÇÃO

IP67
IEC 60529

Con connettore IP67
with connector IP67
Mit Stecker IP67
Avec connecteur IP67
Con conector IP67
Com conector IP67

OPZIONI

OPTIONS
OPTIONEN
OPTIONS
OPCIONES
OPÇÕES

Altre tensioni/potenze su richiesta

Other voltages/powers on request
Andere Spannungen/Leistungen auf Anfrage
Autres tensions/puissances sur demandes
Otras tensiones-potencia bajo pedido
Outras tensões/potências sob encomenda

SERIE E

BOBINA

COIL
SPULE
BOBINE
BOBINA
SOLENÓIDE



36 mm

13 mm

ED 100%



UL 429 & CSA C22.2 NO. 139-13

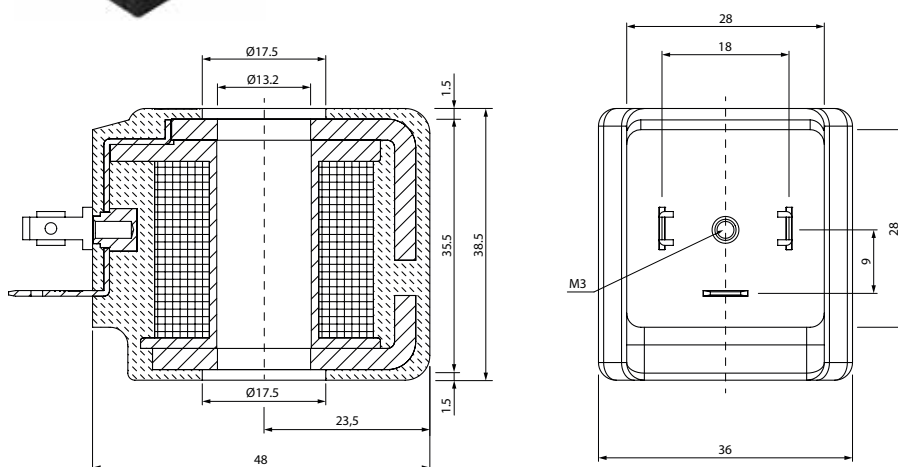

Riferimento Reference Referenz Référéce Referencia Referência	Codice Code Code Code Código Código	Tensione Voltage Leistung Tensión Tensão	Potenza Function Leistung Puissance Potencia Potência	Tolleranze di tensione Voltage tolerance Spannungstoleranz Tolérance de la tension Tolerancia de tensión Tolerância de tensão	Temperatura ambiente Ambient temperature Umgebungstemperatur Température ambiante Temperatura ambiente Temperatura Ambiente	
					Min	Max
EA	SOL21012C7000	12V DC	22 W	±10 %	-10 °C	+80 °C
EB	SOL21024C7000	24V DC	22 W	±10 %	-10 °C	+80 °C
E1	SOL21024AC000	24V AC / 50-60 Hz	31 VA	±10 %	-10 °C	+80 °C
E2	SOL21110AC000	110V AC / 50-60 Hz	31 VA	±10 %	-10 °C	+80 °C
E3	SOL21220AC000	220V AC / 50-60 Hz	31 VA	±10 %	-10 °C	+80 °C

CLASSE DI ISOLAMENTO
INSULATION CLASS
ISOLIERSTOFFKLASSE
CLASSE D'ISOLATION
CLASE DE AISLAMIENTO
CLASSE DE ISOLAMENTO

H
EN 60085

MATERIALE INCAPSULAMENTO
ENCAPSULATION MATERIAL
VERGÜSSMASSE
MATERIAUX EXTÉRIEUR
MATERIAL DE ENCAPSULAMIENTO
MATERIAL DE ENCAPSULAMENTO

RYNITE®

CONNESSIONI ELETTRICHE
ELECTRICAL CONNECTIONS
ELEKTRISCHE ANSCHLÜSSE
CONNEXIONS ELECTRIQUES
CONEXIÓN ELÉCTRICA
CONEXÕES ELÉTRICAS

FORM A
EN 175301-803
(EX DIN 43650)

TEMPERATURA AMBIENTE
AMBIENT TEMPERATURE
UMGEBUNGSTEMPERATUR
TEMPÉRATURE AMBIANTE
TEMPERATURA AMBIENTE
TEMPERATURA AMBIENTE

-10 °C
+80 °C

GRADO DI PROTEZIONE
PROTECTION DEGREE
SCHUTZART
DEGRÉ DE PROTECTION
GRADO DE PROTECCIÓN
GRAU DE PROTEÇÃO

IP67
IEC 60529
Con connettore IP67
with connector IP67
Mit Stecker IP67
Avec connecteur IP67
Con conector IP67
Com conector IP67

OPZIONI
OPTIONS
OPTIONEN
OPTIONEN
OPCIONES
OPÇÕES

Altre tensioni/potenze su richiesta
Other voltages/powers on request
Andere Spannungen/Leistungen auf Anfrage
Autres tensions/puissances sur demandes
Otras tensiones-potencia bajo pedido
Outras tensões/potências sob encomenda

SERIE Y

BOBINA

COIL
SPULE
BOBINE
BOBINA
SOLENOÏDE



50 mm

14 mm

ED 100%



ATEX II 2GD
Ex d IIC T6 o T5 o T4 Gb IP66
Ex tb IIIC T85°C o T100°C o T135°C Db IP66
CESI 03 ATEX 344/02
Tamb -40°C ÷ +35°C(T6) o +50°C(T5) o +60°C(T4)

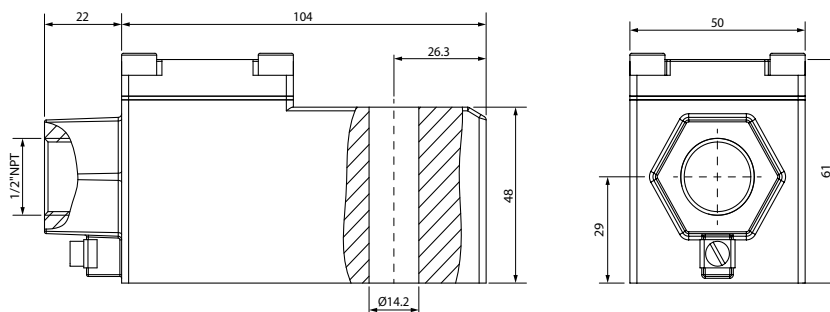

Riferimento Reference Referenz Référéncia Referencia Referência	Codice Code Code Code Código Código	Tensione Voltage Leistung Tension Tensión Tensão	Potenza Function Leistung Puissance Potencia Potência	Tolleranze di tensione Voltage tolerance Spannungstoleranz Tolérance de la tension Tolerancia de tensión Tolerância de tensão
YA	SOLY0012C5000	12V DC	8 W	±10 %
YB	SOLY0024C5000	24V AC / DC	8 W	±10 %
Y2	SOLY0110C5000	110V/120V AC / DC	8 W	±10 %
Y3	SOLY0220C5000	220V/240V AC / DC	8 W	±10 %

CLASSE DI ISOLAMENTO
 CLASS OF ISOLATION
 ISOLIERSTOFFKLASSE
 CLASSE D'ISOLATION
 CLASE DE AISLAMIENTO
 CLASSE DE ISOLAMENTO

H
EN 60085

MATERIALE CUSTODIA
 CASE MATERIAL
 GEHÄUSEMATERIAL
 MATERIAU DU BOITIER
 MATERIAL DE LA CAJA
 MATERIAL DA CAPA

ALUMINIUM

Acciaio Inox su richiesta
 Stainless Steel on request
 Edelstahl auf anfrage
 acier inoxydable sur demande
 acero inoxidable bajo pedido
 aço inoxidável sob encomenda

CERTIFICAZIONI SU RICHIESTA
 CERTIFICATIONS ON REQUEST
 ZERTIFIZIERUNGEN AUF ANFRAGE
 CERTIFICACIONES SUR DEMANDE
 CERTIFICACIONES BAJO SOLICITUD
 CERTIFICAÇÕES SOB ENCOMENDA

EAC
INMETRO
CCOE
PESO
CCC

GRADO DI PROTEZIONE
 DEGREE OF PROTECTION
 SCHUTZART
 DEGRÉ DE PROTECTION
 GRADO DE PROTECCIÓN
 GRAU DE PROTEÇÃO

IP66
IEC 60529

INGRESSO CAVI
 CABLE ENTRY
 KABELDURCHFÜHRUNGEN
 ENTRÉE DE CÂBLE
 ENTRADA DE CABLE
 ENTRADA DE CABOS

1/2" NPT

Su richiesta M20x1.5
 On request M20x1.5
 Auf Anfrage M20x1.5
 Sur demande M20x1.5
 Bajo pedido M20x1.5
 Sob encomenda M20x1.5

VERSIONI SPECIALI
 SPECIAL VERSION
 SONDERAUSFÜHRUNG
 VERSION SPECIALE
 VERSIÓN ESPECIAL
 VERSÕES ESPECIAIS

Su richiesta
 On request
 Auf Anfrage
 Sur demande
 A petición
 Sob encomenda

ALTRE CARATTERISTICHE
 OTHER FEATURES
 ANDERE EIGENSCHAFTEN
 AUTRES CARACTÉRISTIQUES
 OTRAS CARACTERÍSTICA
 OUTRAS CARACTERÍSTICAS

Morsettiera integrata, ingresso cavi orizzontale, soppressore picchi di tensione, doppia guarnizione, condizioni ambientali estreme
 Integrated terminal block, horizontal cable entry, surge suppressor, double gasket, extreme environmental conditions
 Integrierte Klemmleiste, horizontale Kabeleinführung, Überspannungsschutz, doppelte Dichtung, extreme Umweltbedingungen
 Bornier intégré, entrée de câble horizontale, sur-tension, double étanchéité, conditions environnementales extrêmes
 Bloque de terminales integrado, entrada de cable horizontal, supresor de sobretensiones, doble cierre, condiciones ambientales extremas
 Bloco terminal ntegrado, entrada de cabo horizontal, supressor de pico de tensão, dupla vedação, condições ambientais extremas

CONNETTORE

CONNECTOR
STECKER
CONNECTEURS
CONECTOR
CONECTOR

 **22 mm**

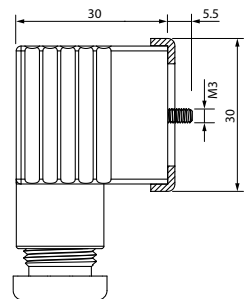
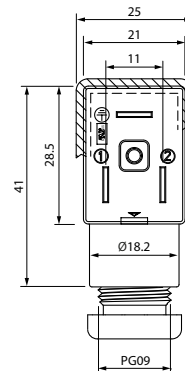
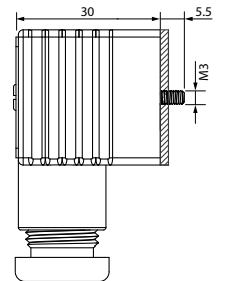
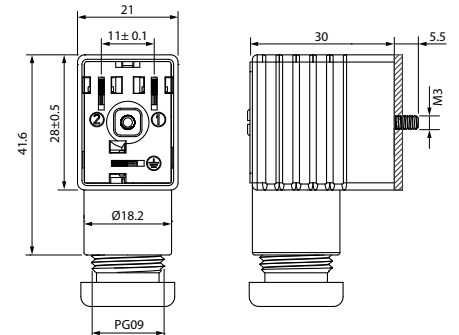

Codice Code Code Code Código Código	Taglia Size Größe Dimensions Talla Tamanho	Colore Colour Farbe Couleur Color Cor	Caratteristiche Characteristics Eigenschaften Caractéristiques Características Características
	mm		
CON01 000 01	22	BLACK	2 POLI - PINS - PINS - BROCHES - PINS - PINOS
CON02 024 00	22	TRANSPARENT	● LED + VDR 0 - 24V
CON02 110 00	22	TRANSPARENT	● LED + VDR 110V
CON02 250 00	22	TRANSPARENT	● LED + VDR 220V
CONU1 000 01	22	BLACK	2 POLI - PINS - PINS - BROCHES - PINS - PINOS

UL 1977 AND CAN/CSA C22.2 NO. 182.3

VDR: Dotati di Varistore come dispositivo di protezione delle sovratensioni.
Fitted with varistors as surge protection device.
Ausgestattet mit Varistor als ÜberSpannungsschutz.
Equipé avec varistance de protection contre les sur Tensions.
Dotado de Varistor como dispositivo de protección de sobretensiones.
Dotados de Varistor como dispositivo de proteção de sobretenção.



Schema elettrico

Wiring

Elektroschema

Schéma électrique

Esquema eléctrico

Esquema elétrico

CON01 000 01
CONU1 000 01

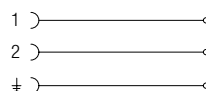

CON02 024 00
CON02 110 00
CON02 250 00

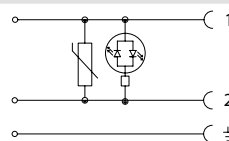

CONNESSIONI ELETTRICHE
ELECTRICAL CONNECTIONS
ELEKTRISCHE ANSCHLÜSSE
CONNEXIONS ELECTRIQUES
CONEXIÓN ELÉCTRICA
CONEXÕES ELÉTRICAS

FORM B
EN 175301-803
(EX DIN 43650)

GRADO DI PROTEZIONE
PROTECTION DEGREE
SCHUTZART
DEGRÉ DE PROTECTION
GRADO DE PROTECCIÓN
GRAU DE PROTEÇÃO

IP67
IEC 60529

DIAMETRO CAVO
CABLE DIAMETER
KABELDURCHMESSER
DIAMÈTRE DU CABLE
DIÁMETRO CABLE
DIÁMETRO DO CABO





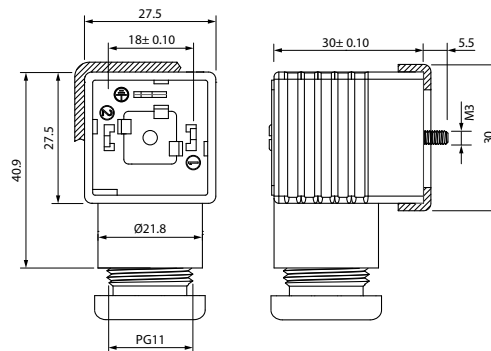
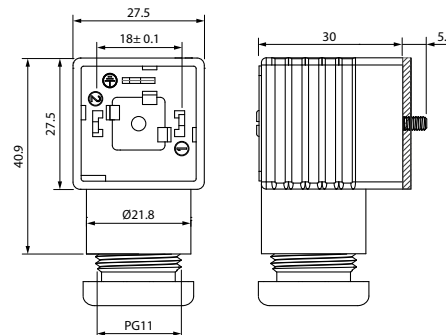

6 ÷ 8 mm

CONNETTORE

CONNECTOR
STECKER
CONNECTEURS
CONECTORE
CONECTOR

 **30-36 mm**



	Taglia Size Größe Dimensions Talla Tamanho	Colore Colour Farbe Couleur Color Cor	Caratteristiche Characteristics Eigenschaften Caractéristiques Características Características
	mm		
CON31 000 01	30 - 36	 BLACK	2 POLI - PINS - PINS - BROCHES - PINS - PINOS
CON32 024 00	30 - 36	 TRANSPARENT	● LED + VDR 0 - 24V
CON32 110 00	30 - 36	 TRANSPARENT	● LED + VDR 110V
CON32 250 00	30 - 36	 TRANSPARENT	● LED + VDR 220V
CONU3 100 01	 30 - 36	 BLACK	2 POLI - PINS - PINS - BROCHES - PINS - PINOS

UL 1977 AND CAN/CSA C22.2 NO. 182.3

VDR: Dotati di Varistore come dispositivo di protezione delle sovratensioni.
Fitted with varistors as surge protection device.
Ausgestattet mit Varistor als ÜberSpannungsschutz.
Équipé avec varistance de protection contre les sur Tensions.
Dotado de Varistor como dispositivo de protección de sobretensiones.
Dotados de Varistor como dispositivo de proteção de sobretenção.



Schema elettrico

Wiring

Elektroschema

Schéma électrique

Esquema eléctrico

Esquema elétrico

CON31 000 01
CONU3 100 01

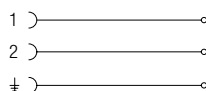

CON32 024 00
CON32 110 00
CON32 250 00

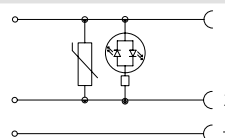

CONNESSIONI ELETTRICHE
ELECTRICAL CONNECTIONS
ELEKTRISCHE ANSCHLÜSSE
CONNEXIONS ELECTRIQUES
CONEXIÓN ELÉCTRICA
CONEXÕES ELÉTRICAS

FORM A
EN 175301-803
(EX DIN 43650)

GRADO DI PROTEZIONE
PROTECTION DEGREE
SCHUTZART
DEGRÉ DE PROTECTION
GRADO DE PROTECCIÓN
GRAU DE PROTEÇÃO

IP67
IEC 60529

DIAMETRO CAVO
CABLE DIAMETER
KABELDURCHMESSER
DIAMÈTRE DU CABLE
DIÁMETRO CABLE
DIÁMETRO DO CABO

6 ÷ 8 mm
&
8 ÷ 11 mm